

Z 1500/...

Mat.: ≈ 1.0727/980 N/mm²

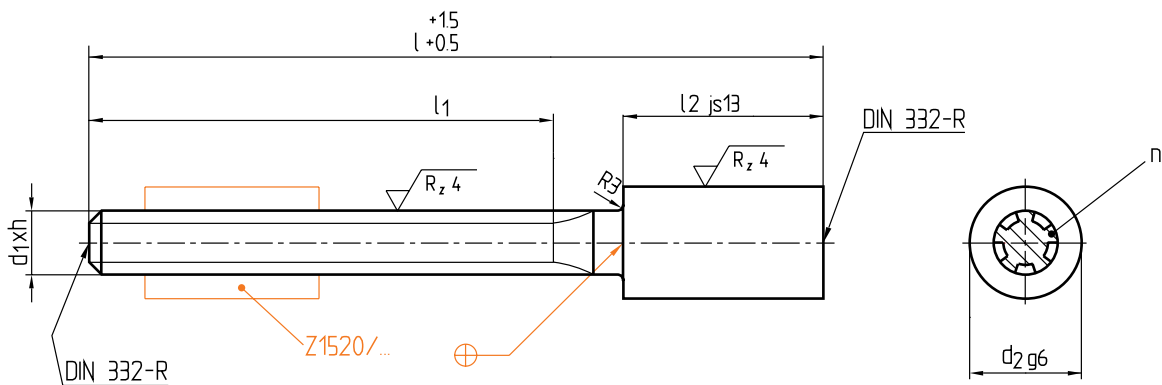

⊖ = Linksgewinde
 ⊖ = Left hand thread
 Filetage gauche

| n | l ₂ | d ₂ | l | d ₁ x h | ⊖ | l ₁ | Nr./No. | | |
|----|----------------|----------------|--------------------|--------------------|------------|----------------------|----------------------|------------|----------------------|
| 5 | 50 | 28 | 240 | Tr 16 x 50 | L | 160 | Z 1500/16x 50/L/160 | | |
| | | | 330 | | | | 250 | 250 | |
| | | | 240 | Tr 16 x 63 | | 160 | Z 1500/16x 63/L/160 | | |
| | | | 330 | | | | 250 | 250 | |
| 6 | 63 | 36 | 345 | Tr 20 x 63 | L | 250 | Z 1500/20x 63/L/250 | | |
| | | | 410 | | | | 315 | 315 | |
| 7 | | | 345 | 410 | | Tr 20 x 80 | 250 | 315 | Z 1500/20x 80/L/250 |
| | | | | | | | | | Tr 20 x 100 |
| 8 | 80 | 45 | 430 | Tr 25 x 80 | L | 315 | Z 1500/25x 80/L/315 | | |
| | | | 515 | | | | 400 | 400 | |
| 9 | | | 430 | 515 | | Tr 25 x 100 | 315 | 400 | Z 1500/25x 100/L/315 |
| | | | | | | | | | Tr 25 x 125 |
| 10 | 100 | 56 | 430 | Tr 25 x 160 | L | 315 | Z 1500/25x 160/L/315 | | |
| | | | 515 | | | | 400 | 400 | |
| 9 | | | 490 | 585 | | Tr 32 x 100 | 355 | 450 | Z 1500/32x 100/L/355 |
| | | | | | | | | | Tr 32 x 125 |
| 10 | 490 | 585 | Tr 32 x 160 | 355 | 450 | Z 1500/32x 160/L/355 | | | |
| | | | | | | 11 | 490 | 585 | Tr 32 x 200 |
| | | | | | | | | | |

This is trial version
www.adultpdf.com

Z 1500/...

Mat.: ≈ 1.0727/980 N/mm²

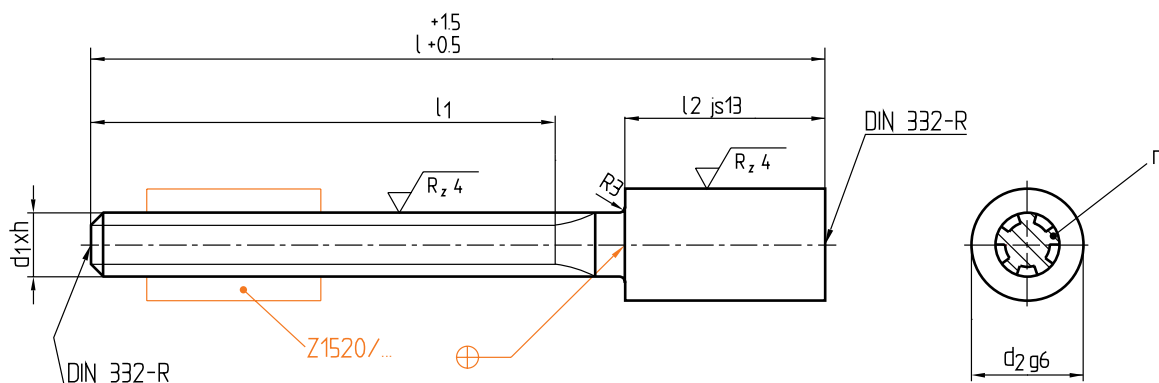

⌚ = Rechtsgewinde
 = Righthand thread
 Filetage droit

| n | l ₂ | d ₂ | l | d ₁ x h | ⌚ | l ₁ | Nr./No. | | | |
|----|----------------|--------------------|-----|--------------------|--------------------|---------------------|---------------------|---|------------|---------------------|
| 5 | 50 | 28 | 240 | Tr 16 x 50 | R | 160 | Z 1500/16x 50/R/160 | | | |
| | | | 330 | | | 250 | 250 | | | |
| | | | 240 | Tr 16 x 63 | | 160 | Z 1500/16x 63/R/160 | | | |
| | | | 330 | | | 250 | 250 | | | |
| 6 | 63 | 36 | 345 | Tr 20 x 63 | R | 250 | Z 1500/20x 63/R/250 | | | |
| | | | 410 | | | 315 | 315 | | | |
| 7 | | | 345 | Tr 20 x 80 | | 250 | Z 1500/20x 80/R/250 | | | |
| | | | 410 | | | 315 | 315 | | | |
| 8 | 80 | 45 | 345 | Tr 20 x 100 | R | 250 | Z 1500/20x100/R/250 | | | |
| | | | 410 | | | 315 | 315 | | | |
| | | | 430 | Tr 25 x 80 | | 315 | Z 1500/25x 80/R/315 | | | |
| | | | 515 | | | 400 | 400 | | | |
| 9 | | | 430 | Tr 25 x 100 | | 315 | Z 1500/25x100/R/315 | | | |
| | | | 515 | | | 400 | 400 | | | |
| 10 | | | 100 | 56 | | 430 | Tr 25 x 125 | R | 315 | Z 1500/25x125/R/315 |
| | | | | | | 515 | | | 400 | 400 |
| | 430 | Tr 25 x 160 | | | 315 | Z 1500/25x160/R/315 | | | | |
| | 515 | | | | 400 | 400 | | | | |
| 9 | 490 | Tr 32 x 100 | | | 355 | Z 1500/32x100/R/355 | | | | |
| | 585 | | | | 450 | 450 | | | | |
| | 10 | 490 | | | Tr 32 x 125 | 355 | Z 1500/32x125/R/355 | | | |
| | | 585 | | | | 450 | 450 | | | |
| 11 | 100 | 56 | 490 | Tr 32 x 160 | R | 355 | Z 1500/32x160/R/355 | | | |
| | | | 585 | | | 450 | 450 | | | |
| | | | 490 | Tr 32 x 200 | | 355 | Z 1500/32x200/R/355 | | | |
| | | | 585 | | | 450 | 450 | | | |

This is trial version
www.adultpdf.com